



A combination of creativity and expert craftsmanship, the **Ala** table is the dominant presence in the living room – the setting for the day-to-day goings-on of domestic life. The round or semi-oval table top, outlined by a border that takes the edge off the thickness, appears suspended in mid-air, almost ready to take flight. The tapered legs only heighten this effect, based on the design of the wings of an aeroplane.

TYPE / TABLES

TECHNICAL DESCRIPTION

*A new platform enriches the **Ala** table collection, 3100 mm in length.*

Tables with wooden base veneered or matt lacquered. Moulded top available in two versions: oval top available in marble top in all variants or in transparent glass; round top available in moulded marble and undertop in moulded

wood same finish as the base. For round top available an optional revolving moulded top in marble (Lazy Susan), is available in two dimensions.

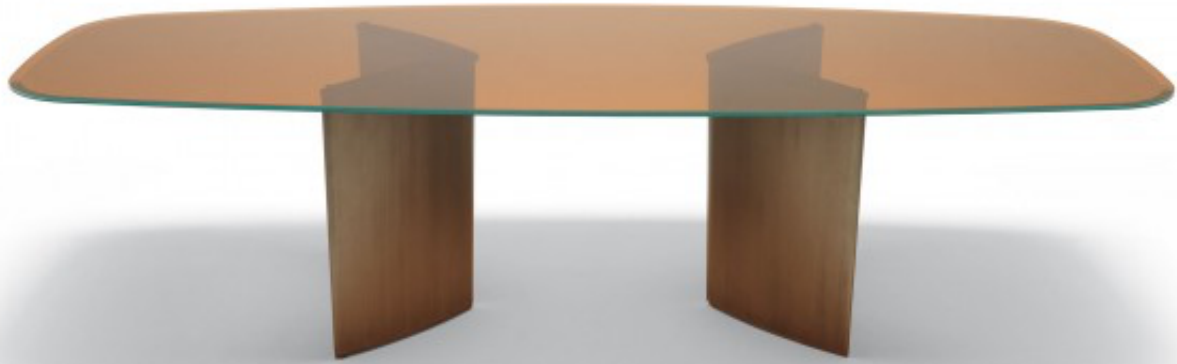

DESIGNER

FERRUCCIO LAVIANI

Born in Cremona in 1960 Laviani attends the Istituto Professionale Internazionale per l'Artigianato Liutario e del Legno di Cremona, receiving his degree in 1978. He later attends the Faculty of Architecture, at the Politecnico di Milano where he graduates in 1986, while attending at the same time the Scuola Politecnica di Design in Milan from 1982 to 1984. In 1983 he starts working for Michele De Lucchi; he becomes a partner in 1986 and works there until 1991, when he decides to open his own studio in Milan. Laviani's work mainly focuses on product design, interior design, art direction and graphic. Since 1991, he is the Art Director for Kartell; same role he has played for other companies. He designs retail spaces and set-ups, offices and houses for private clients, as well as for furniture and fashion. In 2008 an exhibition was dedicated to the lamps he designed for Kartell. Bourgie and Take lamps for Kartell are part of the permanent Collection of IMA, *Indianapolis Museum of Art (USA)*; also other products have been featured in museums and shows all over the world. In 2015, Laviani develops the new concept for Kartell Museum in Noviglio, updating the interior design he had conceived in 1999, when he received the award Premio Guggenheim Impresa & Cultura 2000, as the best museum of a company. Last year, he has started a collaboration with the Italian mosaic brand Bisazza. In 2016 Ferruccio has designed the pop-up store for the fashion designer Paula Cademartori and the set-up for the Haute Couture Women show for Dolce e Gabbana, at Laboratori Ansaldo, Teatro alla Scala, Milan.



TOP FINISHINGS

MATT LACQUERED

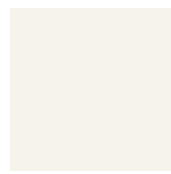

01 Gesso

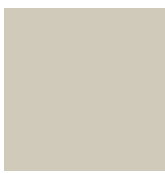

8B Caolino

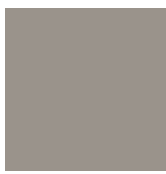

9G Ostrica



6B Grigio
Pietra



14 Nero



02 Talco



9F Sand



4G Argilla



8C
Cappuccino



5B Grigio
Lava



72 Sabbia



8A Beige



9T Toffee

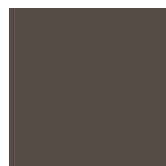

93 Melange



13 Sepia



09 Wengè



New - 12
Vinaccia



New - 68
Melanzana



94 Marsala



95 Ruggine



9B Senape



98 Oliva



New - 8Z
Bosco



9H Petrolio



New - 41 Blu
notte

TRANSPARENT GLASS

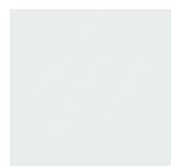

V00 Extra
light



V05 Fumé

MARBLES

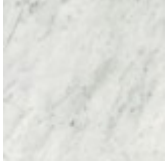

BC Bianco
Carrara
natural matt



CA Calacatta
Oro natural
matt

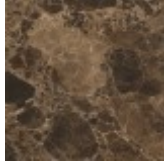

EM
Emperador
natural matt



TV
Travertino
natural matt



BA Basaltite
natural matt

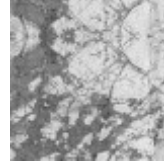

IG Invisible
Grey natural
matt



GT Grey
Stone
natural
glossy

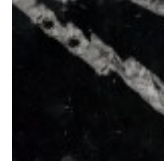

MR
Marquinia
natural
glossy

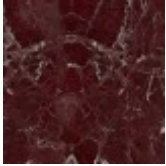

RL Rosso
Lepanto
natural
glossy



OR Orobico
natural
glossy

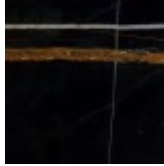

SR Sahara
Noir glossy
polyester

MATT VENEERS



50 Rovere
cenere



53 Elm grey



51 Black oak

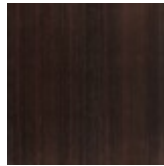

66 Tobacco

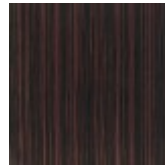

62 Ebony



54
Eucalyptus

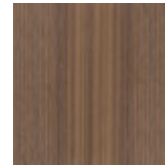

67 Noce
Canaletto

GLOSSY VENEERS



L62 Ebony

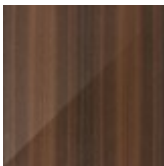

L54
Eucalyptus

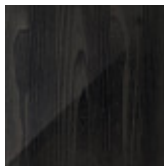

L51 Black
Oak

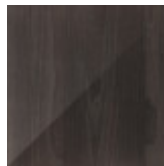

L53 Grey
Elm

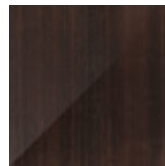

L66 Tobacco

BASE FINISHINGS

MATT LACQUERED



01 Gesso 8B Caolino 9G Ostrica 6B Grigio Pietra 14 Nero 02 Talco 9F Sand 4G Argilla



8C Cappuccino 5B Grigio Lava 72 Sabbia 8A Beige 9T Toffee 93 Melange 13 Sepia 09 Wengè



New - 12 Vinaccia New - 68 Melanzana 94 Marsala 95 Ruggine 9B Senape 98 Oliva New - 8Z Bosco 9H Petrolio



New - 41 Blu notte

LACQUERED METALS ANTIQUED

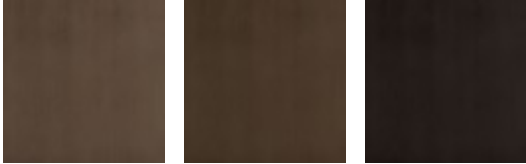

7R Ottone Anticato 5R Dark Bronze Anticato 6R Graphite Anticato

MATT VENEERS

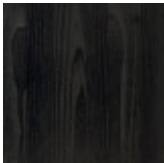

51 Black oak

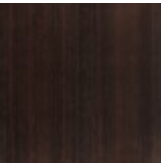

66 Tobacco

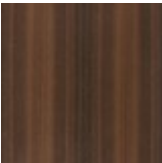

54
Eucalyptus

DIMENSIONS

Oval table W. 2500 mm

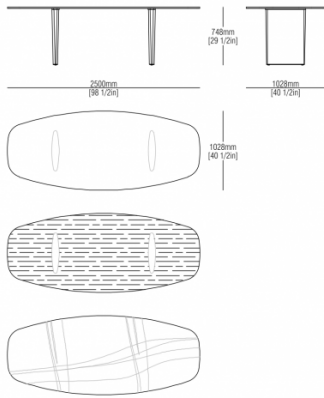

Oval table W. 2800 mm

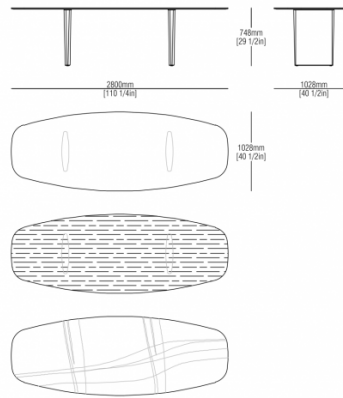

Oval table W.3100 mm

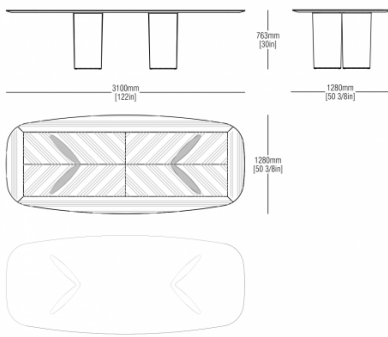

Round table W.1550 mm

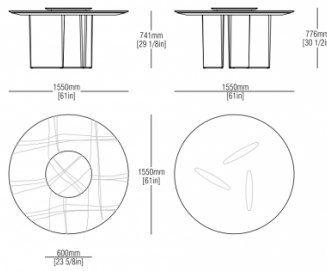

Round Table W. 1550 mm

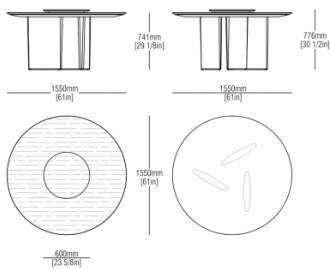

Round marble table W.1650 mm

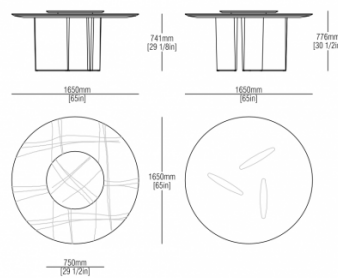

Wood round table W.1650 mm

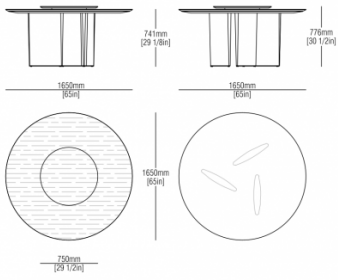

Round marble table W. 1800 mm

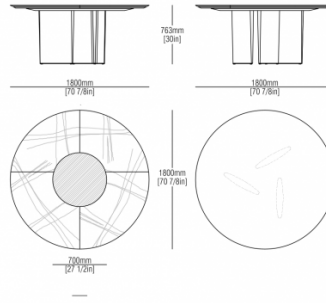

Round wood table W. 1800 mm

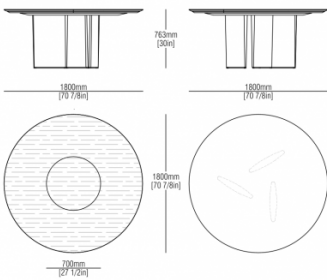

Round marble table W. 2000 mm

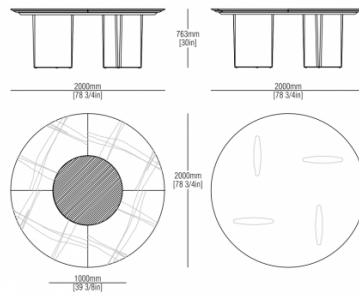

Wood round table W. 2000 mm

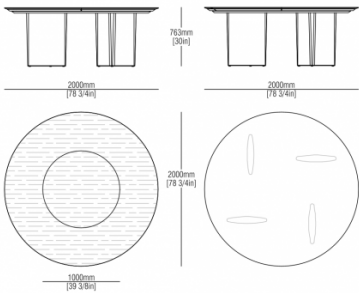

Round marble table W. 2200 mm

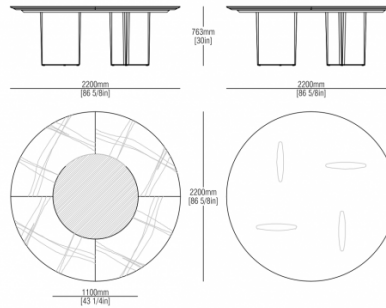

Wood round table W. 2200 mm

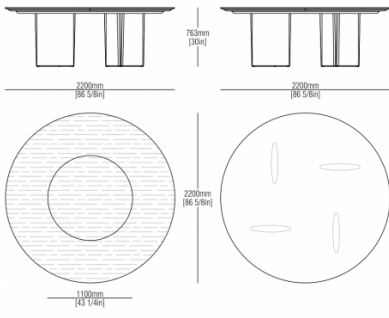

Round marble table W. 2400 mm

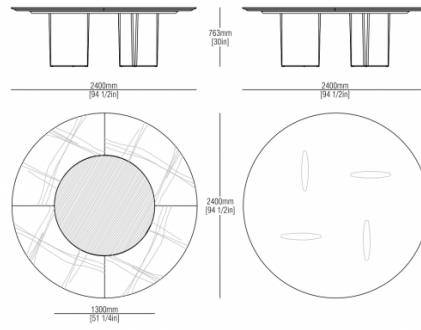

Wood round table W. 2400 mm

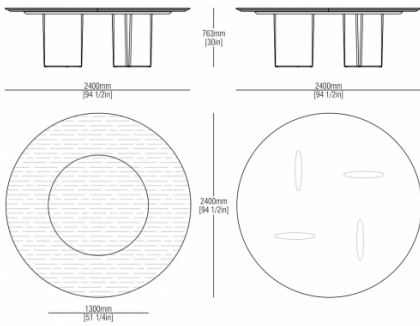

MisuraEmme®